



MPMS Application Note 1014-210

Oxygen Contamination

This application note describes potential sources for oxygen contamination in the sample chamber and discusses its possible effects. Molecular oxygen, which undergoes an antiferromagnetic transition at about 43 K, is strongly paramagnetic above this temperature. The MPMS system can easily detect the presence of a small amount of condensed oxygen on the sample, which when in the sample chamber can interfere significantly with sensitive magnetic measurements. Oxygen contamination in the sample chamber is usually the result of leaks in the system due to faulty seals, improper operation of the airlock valve, outgassing from the sample, or cold samples being loaded.

Oxygen Leaking into the Sample Chamber

The sample chamber in the MPMS is leak-proof with respect to the ambient room atmosphere. A 5mm Hg pressure of helium gas is normally maintained in the sample chamber to provide for thermal exchange between the sample and the sample chamber walls. As the pressure in the sample chamber falls much lower than the ambient room pressure, any leaks that might develop will result in a steady flow of air into the sample chamber.

Large and Small Air Leaks

Large air leaks in the sample chamber, caused by a missing o-ring, for example, can cause the green ready light not to light up at the end of the airlock purging cycle. The green light doesn't light up because the pressure in the sample chamber isn't falling low enough to trigger the indicator lamp. Smaller leaks, however, can allow a continuous flow of air molecules into the sample chamber without significantly affecting the background pressure in the sample chamber.

Leaks at Low and High Temperatures

Accumulated oxygen is a consequence of an air leak in the sample chamber, particularly when making measurements below 100 K. At higher temperatures, oxygen that enters the sample chamber will diffuse out to the vacuum pump, resulting in a low concentration of oxygen in the sample chamber. Therefore, at higher temperatures the small amount of oxygen will have relatively little effect on the measurements.

Contamination at Lower Temperature

At lower temperatures, particularly below 100 K, the walls of the sample chamber, the sample rod, and even the sample itself act as cryopumps that cause the incoming oxygen to continuously condense on the cold surfaces. The easiest way to detect oxygen contamination

on your sample is to look for the antiferromagnetic transition in oxygen at 43 K as you are measuring the temperature dependence of your sample. The presence of this highly paramagnetic condensate can interfere with sensitive magnetic measurements by:

- giving incorrect values of the measured moment and introducing incorrect temperature and field dependencies into the data.
- making the antiferromagnetic transition of the oxygen contamination appear as an increased paramagnetism in the sample at about 43 K if the sample moment is measured as a function of temperature.
- making the standard deviation of the individual measurements higher than normal due to oxygen either condensing onto or evaporating off of the sample from one scan to the next if several scans are averaged together. As long as the temperature of the sample chamber walls and the sample itself are still settling, oxygen will continually move about the sample chamber, evaporating from one surface only to condense on another.
- allowing the standard deviations to decrease to a level typical of normal operation if additional time is allowed for the MPMS system temperature to stabilize. However, if the system is contaminated with oxygen, this means only that the oxygen is not moving appreciably during the time required to collect the data at one temperature.

Figure 1 shows the temperature dependence of the magnetic susceptibility of solid oxygen. Figure 2 and Figure 3 show the effect of oxygen contamination on measurements of a palladium reference sample.

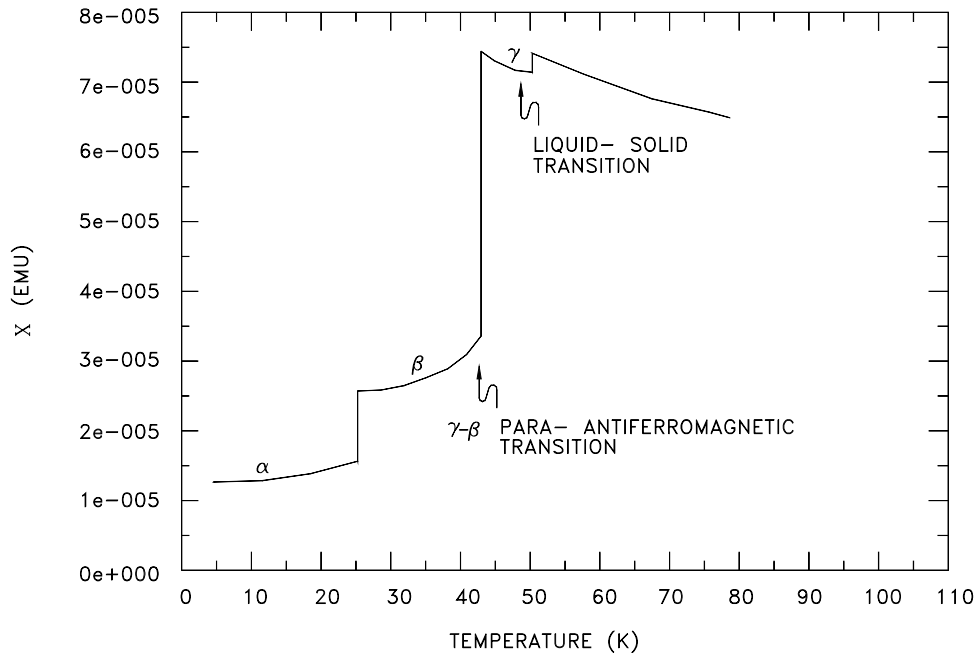

Figure 1. Temperature Dependence of the Magnetic Susceptibility of Solid Oxygen. The curve represents the susceptibility of 250.1 mg of bulk oxygen, redrawn from Stephen Gregory's paper [Physical Review Letters *40*, 723 (1978)]. α , β , and γ are three different phases of solid oxygen. α and β are anti-ferromagnetic, whereas γ is paramagnetic. It is important to note that the $\beta - \gamma$ paraantiferromagnetic transition is a sharp step only for bulk solid oxygen. It is likely that any small leak into the MPMS sample chamber will result in a condensed film of oxygen rather than the bulk solid. This will tend to broaden the step transition, as in Figure 2 and Figure 3. The thinner the condensed film, the smaller and broader is the transition.

Please see the reference listed above for further details.

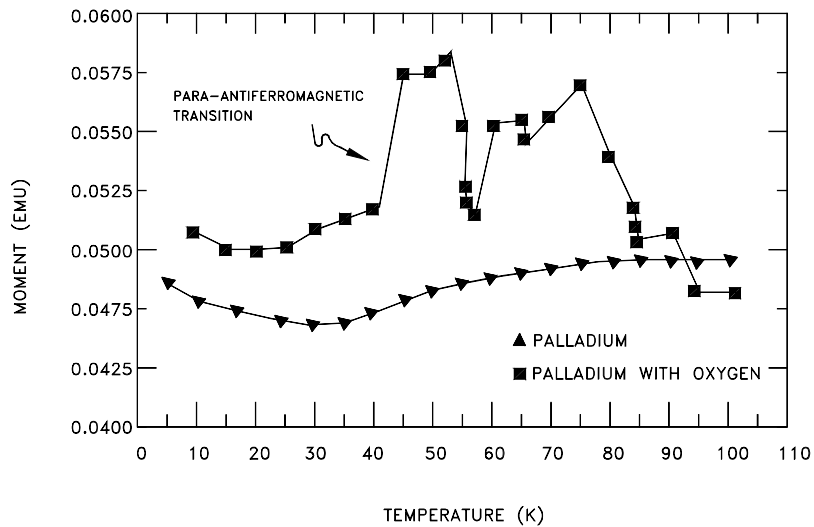

Figure 2. The Effect of Oxygen Contamination on Measurements of a Palladium Reference Sample. The triangles represent the measured moments of a 0.2655g palladium sample in a 3 tesla field at various temperatures from 5 K to 100 K. The squares represent the measured moments of the same palladium sample in the same field. However, about 5.6×10^{-3} moles of oxygen were added to the sample chamber in addition to the few torr of helium already present. The sample chamber was then sealed off, trapping the oxygen.

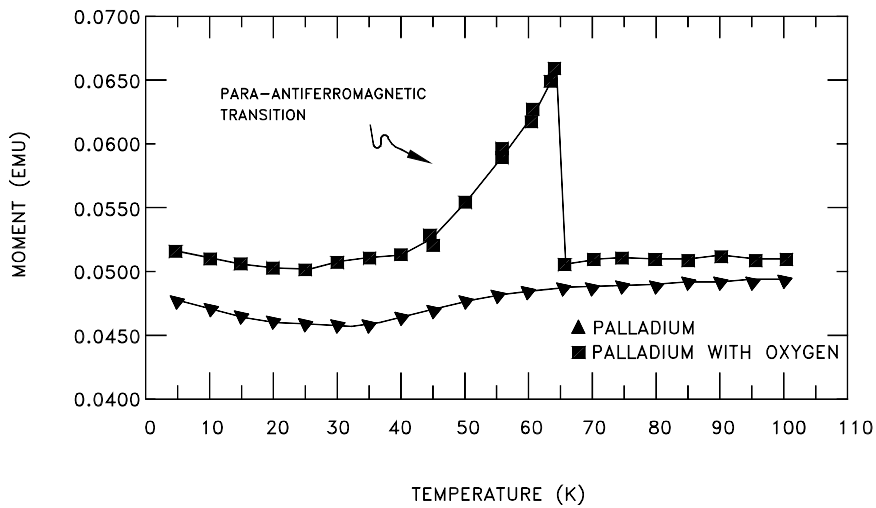

Figure 3. The Effect of Oxygen Contamination on Measurements of a Palladium Reference Sample that was introduced at 5K. The triangles represent the measured moments of the palladium sample (as in Figure 2) in a 3-tesla field. The squares represent the measured moments of the same palladium sample contaminated with about 5.6×10^{-3} moles of oxygen in a 3-tesla field. The difference from Figure 2 is that here the oxygen was added at 5K, and the system was warmed as measurements were made with the MPMS in normal mode (the sample tube was open to the pump). This results in the oxygen pumping away around 65K, resulting in a sharp step. It should be noted that the temperature at which the oxygen is pumped away is likely to be different for differing levels of contamination.

Removing Oxygen Contamination in the Sample Chamber

1. Raise the system temperature to about 250 K so that there won't be any cold spots above the sample chamber where the oxygen can recondense.
2. With the airlock valve open, press **PURGE AIRLOCK** on the front of the MPMS probe. This allows the system to carry out a purge cycle. This is similar to purging air from the airlock when loading a sample, except that the entire sample chamber will be flushed and purged instead of just the airlock.
3. If oxygen is building up in the sample chamber during a measurement sequence, use sequence control to purge the sample chamber to cleanse the sample chamber of oxygen. However, if the oxygen contamination is coming from a leak in your system, the oxygen will soon reappear. The level of contamination will increase steadily with time as the gas continuously condenses onto the cold surfaces in the sample chamber. If you are observing continual oxygen buildup in your instrument, perform a leak test for the sample chamber.

Performing a Leak Test in the Sample Chamber

If you observe oxygen contamination with your sample, check the sample chamber for leaks. Figure 4 shows the positions of the seals to be tested.

1. Set the system temperature to 310 K. Once the temperature has stabilized, load a sample rod without a sample in the instrument as if you are going to make a measurement.
2. Leave an atmosphere of helium gas in the sample chamber by activating **Vent Sample Space**.
3. Disconnect the smaller flexible pumping line at the rear of the MPMS control console and connect this line to a helium leak detector. If you need an adapting connector to connect the pumping line to your leak detector, please contact your Quantum Design service representative.
4. Vent and flush the sample chamber with air (not helium) several times to eliminate the background signal from the helium that is already in the sample chamber. You must flush the sample chamber through your leak detector. Do not use the MPMS controls.
5. Open and close the airlock several times to release helium trapped in the grease of the o-rings.
6. Once the helium leak detector is operating, you can find the leak in the system by spraying helium gas around each of the sealing areas indicated in Figure 4. To test the seals around the airlock, spray helium gas into the hole around the airlock valve shaft that protrudes from the front of the unit. If a leak is there, contact your Quantum Design service representative.
7. If you find a leak around the slide seal assembly, clean and re-lubricate the o-rings underneath the slide seal assembly (replace them if they are cracked or damaged) and perform the leak test again.
8. The test may be repeated using a different slide seal assembly each time you test each of your slide seal and sample rod assemblies.

9. After the tests are completed, reconnect the flexible pumping line to the rear of the MPMS console. Press **PURGE AIRLOCK** on the front of the unit to restore the system to its operating condition.

Sources of Oxygen Contamination from Assemblies in the System

The sample chamber on each unit is thoroughly tested before shipment to ensure there are no leaks between the sample chamber and the ambient atmosphere. However, under steady use of the instrument, oxygen can be introduced into the sample chamber through several mechanisms or by a leak at one of the seals between the sample chamber and the ambient atmosphere. The locations of the various seals protecting the sample chamber are shown in Figure 4.

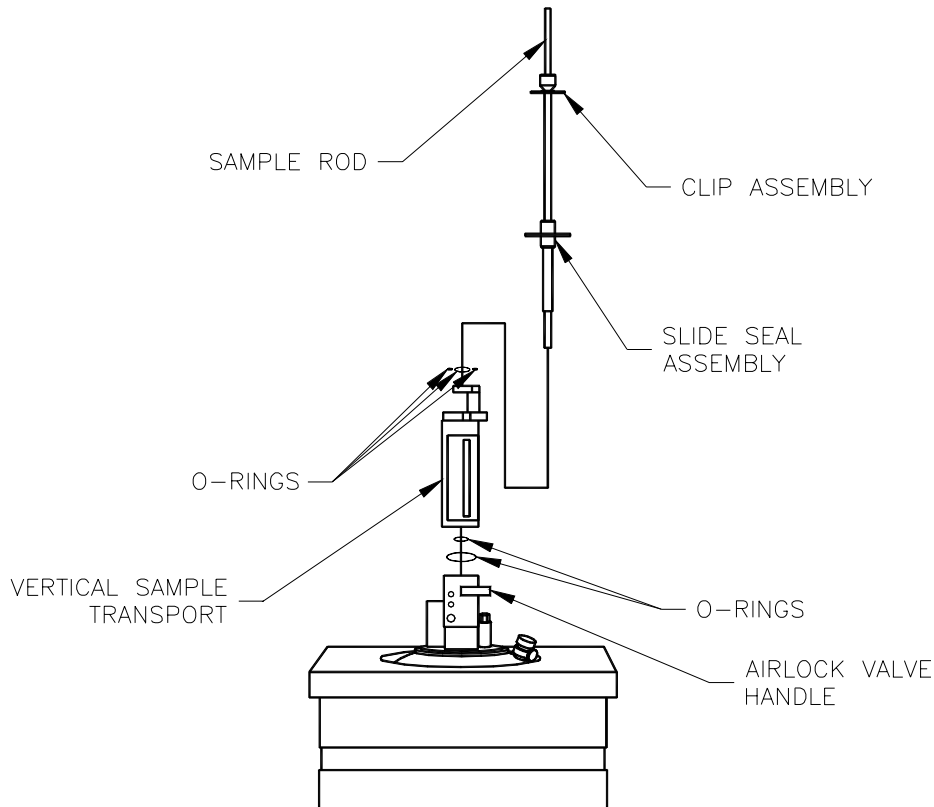

Figure 4. The Slide Seal Assembly

Air Leaks at the Slide Seal Assembly

Lip seals experience the greatest amount of wear and are the most likely sources for air leaks. Lip seals are inside the blue plug of the slide seal assembly where the sample rod enters the sealed sample chamber. The slide seal assembly provides a double sliding lip seal for the sample rod so that helium gas from the dewar constantly flows through the region between the seals. This gas is then exhausted through the hose fitting on the rear of the sample transport mechanism. Air is dragged through the upper seal, diluted by the helium gas between the seals, and to a large extent, carried away by the flowing stream of helium.

If the lip seals are damaged, air will continuously leak through both seals and directly into the sample chamber. In this case the slide seal assembly must be disassembled and the lip seals replaced. You can return slide seal assemblies to the factory to be rebuilt purchase required parts from Quantum Design if you wish to rebuild the units yourself. Contact your Quantum Design service representative for additional information.

Quantum Design recommends replacing the lip seals in the slide seal assemblies at least once a year. Using a liberal amount of Apiezon M grease on the stainless steel sample rods keeps the seals well lubricated and makes them last longer. Also, when you remove a cold sample from the sample chamber, lift the rod slowly so that the sample rod can warm up before it is pulled through the lip seals. Drawing the sample rod through the lip seals while the grease and sample rod are cold causes them to freeze at the sealing point and tear.

Air Leaks in Seals at the Top of the Sample Transport Unit

Air leaks can also develop around the three o-rings directly under the slide seal assembly when the o-rings become dry or cracked or dirt and dust have accumulated around them. Leaks here can usually be repaired quickly and easily. Always keep the airlock valve in the closed position when performing this operation to allow easy retrieval of the small o-rings. It is easy to drop one down the sample port.

1. Remove the sample and close the airlock valve. If any of the o-rings are cracked or damaged, contact your service representative for replacements.
2. Remove and clean the o-rings and their grooves.
3. Apply a small amount of vacuum grease to the o-rings and reinstall them.

Air Leaks in Seals under the Sample Transport

A less likely place for an air leak is the double o-ring seal under the sample transport mechanism (see Figure 4).

1. Remove the sample transport mechanism to reach the o-rings.
2. Remove the sample and close the airlock valve. Remove the four screws that hold the transport mechanism in place (two at the front and the rear).
3. Lift the sample transport unit off the top of the probe. You can now remove the o-rings.

If they are cracked or damaged, replace them with spares from the MPMS Utility Kit. Before reinstalling the o-rings and sample transport, clean the o-rings and the o-ring grooves and re-lubricate the o-rings with vacuum grease.

Other Sources of Air Leaks

Other seals from which air can leak into the sample chamber are located at the top and bottom of the sight glass at the front of the sample transport and around the airlock valve assembly. Replacing any of these seals requires parts and more detailed assistance from your service representative. If you have checked the system for leaks and have definitely identified an air leak at one of these locations, contact your service representative for further assistance.

Venting the Sample Chamber to Ambient Environment

Even if the sample chamber is completely leak-tight, oxygen can enter the sample chamber if the airlock valve is opened and the top of the sample transport is opened to the ambient atmosphere.

If the sample chamber temperature is sufficiently cold when exposed to the atmosphere, air will immediately begin to solidify onto the walls of the sample chamber.

If the airlock is subsequently closed and a new sample installed in the machine in the normal manner, frozen atmospheric gasses will still be trapped in the sample chamber. In this case, purging the airlock and sample chamber can eliminate the contamination problem. However, to purge water vapor and carbon dioxide, the sample chamber temperature should be increased to about 350 K for 10-15 minutes before purging the sample chamber.

Outgassing of Samples

Oxygen can also accumulate in the sample chamber as a result of outgassing from samples or from air condensing on samples that are already cold when loaded into the instrument. If such samples are run continuously, and the sample chamber is never warmed up to evaporate the condensed oxygen, the oxygen contamination can become large enough to interfere with your measurements. Periodically warming the system to 250 K and purging the airlock and sample chamber can avoid this problem.